

HEADWORKS BIOLOGY SEPARATION MEMBRANE ► DISINFECTION BIOSOLIDS SYSTEMS					
	UV DISINFECTION	VERTICAL LAMP SYSTEM	LOW PRESSURE HIGH OUTPUT	WASTEWATER	► Applications - Wastewater Disinfection - Wastewater Reuse - CSO (Combined Sewer Overflow)



► Main characteristics

- Low Pressure High Output lamps
- Rated for outdoor/indoor use
- Vertical cross flow design
- Future upgrade flexibility

The Aquaray® 40 HO (High Output) Vertical Lamp System offers powerful UV output within a reduced footprint while providing the degree of disinfection required for even the most stringent of effluent criteria, such as Wastewater Reuse applications.

MAIN FEATURES

<p>→ Easy maintenance: Due to the vertical design, the Aquaray® 40 HO provides easy access to the UV lamps and quartz sleeves (no need to remove the UV module from channel)</p> <p>→ Save space: To minimize the footprint, the Aquaray® 40 HO utilizes Low Pressure High Output lamps in a vertical design</p>	<p>→ Energy conservation: With a combination of efficient ballasts and row-by-row lamp switching increments, the Aquaray® 40 HO ensures energy conservation by dose pacing based on flow rate signal and UV transmittance</p> <p>→ Validated performance: The Aquaray® 40 HO has been third party validated and completed strict bioassay testing</p>
--	---

UV TECHNOLOGY: Aquaray® 40 HO

The Aquaray® 40 HO Vertical Lamp Ultraviolet Disinfection System has been designed to provide disinfection for wastewater plants within a small footprint. The germicidal effect of the UV light inactivates most micro-organisms such as bacteria, viruses and parasites, while eliminating the need for dangerous chemicals.

The UV dose (UV intensity x contact time) defines the treatment efficiency which is provided by the unit. The effective dose applied depends on the UV transmittance of water to be treated as well as the proper hydraulic design of the UV system.

HOW IT WORKS

The low pressure high output lamps are powered by electronic ballasts to generate germicidal wavelengths of the UV spectrum. The lamps are inserted in quartz sleeves and isolated from the wastewater while delivering the required effluent inactivation. UV sensors are installed to monitor the UV intensity from the lamps and guarantee that the proper intensity is delivered. The

periodic maintenance of the system has been made simple and efficient by allowing the replacement of the lamps without removal of the submerged UV modules from the channel.

TECHNICAL DATA

Model	Flow Rate per module	Number of lamps per module	Electrical Power per lamp
	m ³ /h		W
Aquaray® 40 HO	315 to 500	40	165

Based on 30 mJ/cm² and 65% UVT

► Materials

- 316 stainless steel frame and enclosure
- Teflon wiper rings
- UV resistant materials

► Standards

- Power Supply: 400V/3ph/50-60Hz
- Neutral Network: TNS
- Protection Class: IP 65

- Lamp Type: low pressure high output
- Ballast Type: electronic
- Lamp configuration: vertical cross flow
- Average lamp life: 13 000 hours

► Options

- UVT Analyzer
- In-Channel Air Scrub
- Lifting Apparatus
- Chemical cleaning system

► Remote control and alarms

- SCADA communication capability
- Dose pacing via external flow signal and UV transmittance
- Various alarms (low UV intensity, failed adjacent lamps, etc...)

DIMENSIONS

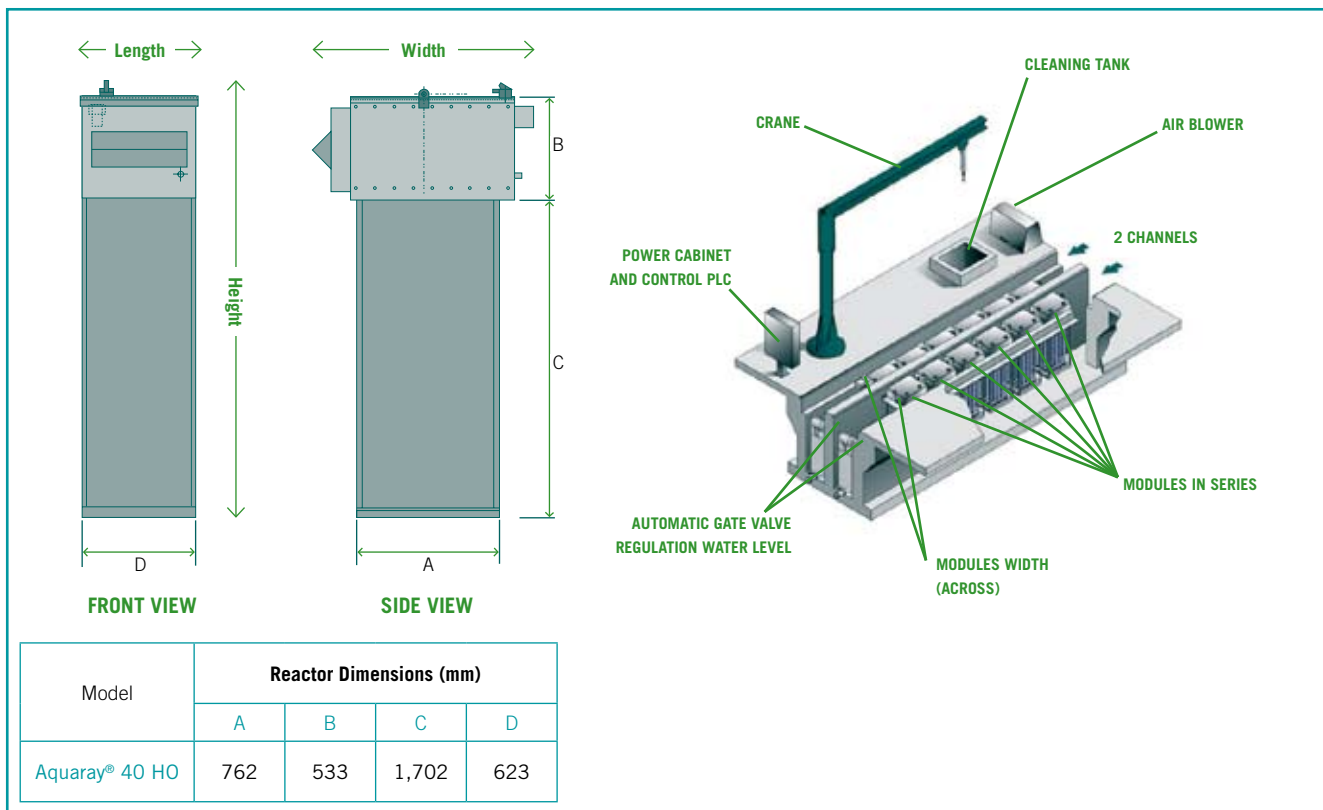

Contacts www.degremont-technologies.com

- | | | |
|---|--|----------------------|
| Degrémont Technologies - Ozonia - France | • info-ozoniaFR@degtec.com | • + 33 1 46 25 39 50 |
| Degrémont Technologies - Ozonia - North America | • info-ozonia@degtec.com | • + 1 201 794 3100 |
| Degrémont Technologies - Ozonia - Switzerland | • info-ozoniaCH@degtec.com | • + 41 44 801 8511 |
| Degrémont Technologies - Ozonia - Russia | • info-ozoniaRU@degtec.com | • + 7 8314 166 256 |
| Degrémont Technologies - Ozonia - Korea | • info-ozoniaKR@degtec.com | • + 82 31 7019036 |
| Degrémont Technologies - China | • info-china@degtec.com | • + 86 10 6597 3860 |
| Degrémont Technologies - Japan | • info-japan@degtec.com | • + 81 3 5444 6361 |

Your local distributor :