



HEADWORKS
BIOLOGY
SEPARATION
MEMBRANE
▶ **DISINFECTION**
BIOSOLIDS
SYSTEMS

UV DISINFECTION **MEDIUM PRESSURE** **DRINKING WATER** **PROCESS WATER**



- ▶ Applications
- Drinking water
 - Process water
 - Aquaculture
 - Deozonation
 - TOC Reduction
 - Ballast water
 - Cooling tower
 - Advanced oxidation

- ▶ Main characteristics
- Multi emission medium pressure Lamp
 - Power step regulation
 - Simple control logic

The Aquaray® SMP-DW/PW range offers compact and high efficiency system for small and medium water plant with a range of flow rates from 22 to 440 m³/h with exceptional reliability and ease of operation.

MAIN FEATURES

- Polychromatic medium pressure lamps for highest germicidal efficiency
- Fewer lamps
- Easy to install in new or existing water plants
- User friendly operator interface microprocessor controlled
- Data logging for up to one year

UV TECHNOLOGY: SMP-DW/PW

The Aquaray® SMP-DW/PW units have been designed to disinfect potable or process water. The germicidal effect of the UV light inactivates most micro-organisms such as bacteria, viruses and parasites. UV is known to be particularly efficient to inactivate *Cryptosporidium Parvum* and *Giardia Lamblia*.

The medium pressure lamps have an action on nucleic acid and proteins for micro-organisms inactivation. The UV dose (UV intensity x contact time) defines the treatment efficiency which is provided by the unit. The effective dose applied depends on the UV transmittance of water to be treated as well as the proper hydraulic design of the unit.

HOW IT WORKS

The medium pressure lamps are powered by magnetic ballasts. The lamps are inserted in pure quartz sleeves isolating them from the water. The lamps can be easily changed when indicated by the micro-processor control unit.

A UV sensor is installed to monitor UV radiation. An optimal wiper system is available for cleaning the UV lamp quartz sleeve.

TECHNICAL DATA

Aquaray® SMP-DW/PW Model	Flow Rate ⁽¹⁾	Lamp Power
	m ³ /h	kW
SMP 100-75-1/2	22	1.5
SMP 100-75-1	44	3
SMP 150-100-1	79	3
SMP 200-150-1	109	3
SMP 250-150-1	136	3
SMP 250-200-1	272	6
SMP 300-250-1	319	6
SMP 300-250-2	440	12

(1) Based on 40 mJ/cm² UV dose at 95% UV transmittance

Materials

- **Reactor Material:** 316L stainless steel/quartz sleeve/
silicon O-ring
- **Panel Material:** polyester coated mild steel

Standards

- **Flanges:** BS, ANSI
- **Reactor Pressure Rating:** 10 barg
- **Electrical:** CE, EN
- **Main Power Supply:** 400V/3ph/50-60 Hz
- **Panel Rating:** IP54
- **Conformity:** CE

Remote controls and alarms

- **Digital Inputs:** lamp start-stop, water flow interlock
- **Digital Outputs:** system status, pre-alarm, alarm
- **Analogue Output:** remote indication of UV intensity

Options

- **Manual or automatic wiper**
- **Power step regulation**
- **Stainless steel panel**

DIMENSIONS

Aquaray® SMP-DW/PW Model	Reactor Dimensions (mm)													Panel: l x h x w	IN-OUT
	A	B	C	D	E	F	G	H	J	K	L	M	N	mm	inch
SMP 100-75-1/2	100	125	700	145	1065	175	900	700	70	100	100	350	285	600 x 800 x 200	3
SMP 100-75-1	100	125	700	145	1065	175	900	700	70	100	100	350	285	600 x 800 x 200	3
SMP 150-100-1	150	150	650	170	1065	225	900	700	120	150	125	350	285	600 x 800 x 200	4
SMP 200-150-1	200	175	600	195	1065	275	900	700	170	200	150	350	285	600 x 800 x 200	6
SMP 250-150-1	250	200	600	195	1065	325	900	1000	220	250	175	350	285	600 x 800 x 200	6
SMP 250-200-1	250	200	600	220	1415	325	1250	1000	220	250	175	350	285	800 x 1000 x 300	8
SMP 300-250-1	300	250	900	220	1415	375	1250	1000	270	300	200	350	285	800 x 1000 x 300	10
SMP 300-250-2	300	250	900	220	1415	375	1250	1000	270	300	200	350	285	800 x 1000 x 500	10

Size connection flanges confirmed with proposal

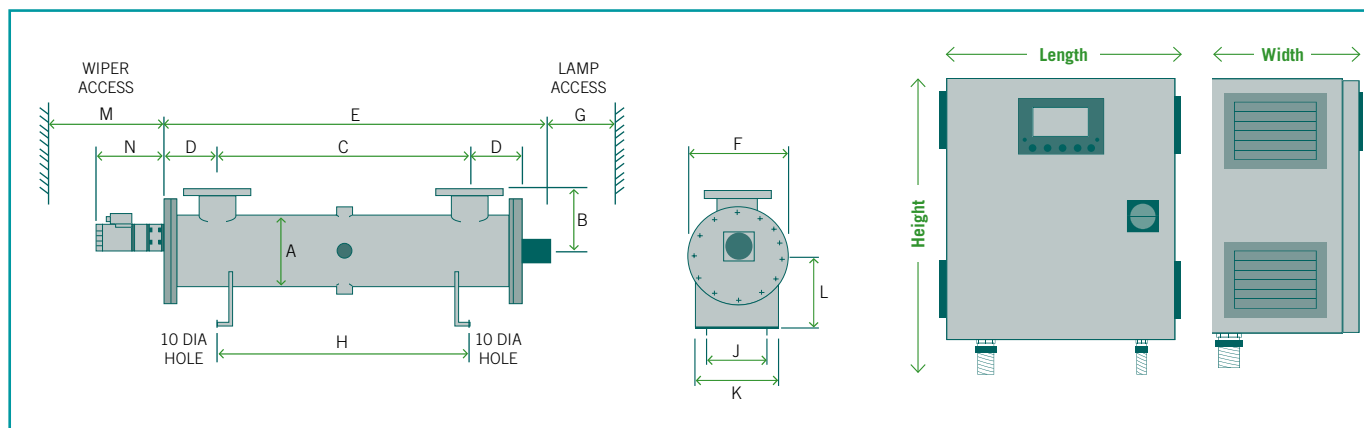

Contacts www.degremont-technologies.com

- | | | |
|---|--|----------------------|
| Degrémont Technologies - Ozonia - France | • info-ozoniaFR@degtec.com | • + 33 1 46 25 39 50 |
| Degrémont Technologies - Ozonia - North America | • info-ozonia@degtec.com | • + 1 201 794 3100 |
| Degrémont Technologies - Ozonia - Switzerland | • info-ozoniaCH@degtec.com | • + 41 44 801 8511 |
| Degrémont Technologies - Ozonia - Russia | • info-ozoniaRU@degtec.com | • + 7 8314 166 256 |
| Degrémont Technologies - Ozonia - Korea | • info-ozoniaKR@degtec.com | • + 82 31 7019036 |
| Degrémont Technologies - China | • info-china@degtec.com | • + 86 10 6597 3860 |
| Degrémont Technologies - Japan | • info-japan@degtec.com | • + 81 3 5444 6361 |
| Degrémont Technologies - Triogen | • info-triogen@degtec.com | • + 44 141 810 48 61 |

Your local distributor :